

Name: _____
Date: _____
Track: _____

Track Conditions

Size: Open Med. Tight
 Traction: High Med. Low
 Surface: Smooth Med. Bumpy

Front suspension

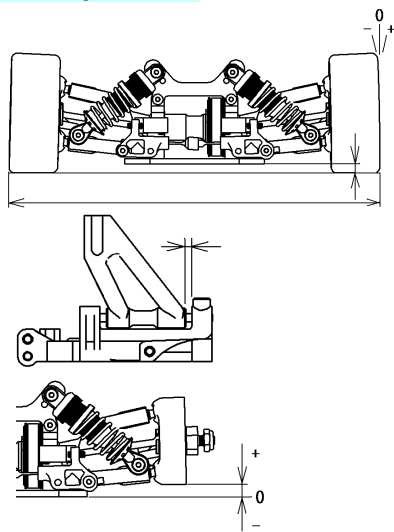

Track width 199 mm
 Ride height 4 mm
 Camber angle -2 °
 Caster angle 2 mm
 Toe angle out 0.5 °
 Rebound stop 2 mm
 Bump stop
 None Use

Anti-roll bar

Steering Ackerman (T0304)

A B C

Front shocks

Piston stock
 Oil # stock
 Spring stock

Shock position

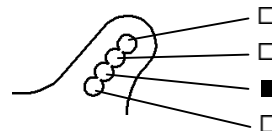

Front diff.

Gear diff.
 Oil # _____
 One way

Rear suspension

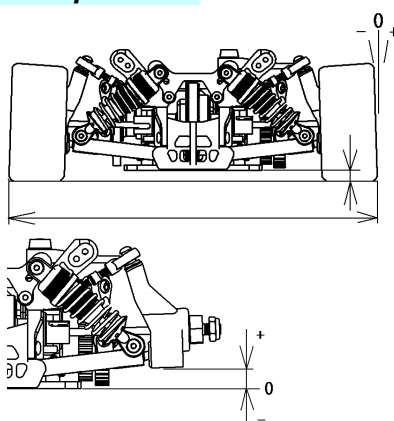

Track width 200 mm
 Ride height 5 mm
 Camber angle -3 °
 Toe angle in 2.5 °
 Rebound stop 6 mm
 Bump stop
 None Use

Lower arm position(T0128,T0129)

4mm(A-A) 5mm(B-B) 6mm(C-C)

Anti-roll bar stock mm

Upper arm position



Rear shocks

Piston stock
 Oil # stock
 Spring stock

Shock position

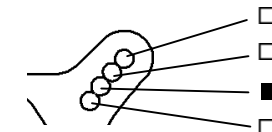

Rear diff.

Oil # stock

Engine

Type _____
 Gasket _____ mm Muffler _____
 Plug _____ Fuel _____

Clutch

Clutch shoes Black Gray
 Centrifugal shoe stock
 Spring _____

Tire

Front	Rear
Type <u>stock (37°)</u>	Type <u>stock (37°)</u>
Dia.(start) <u>L /R</u>	Dia.(start) <u>L /R</u>
Dia.(finish) <u>L /R</u>	Dia.(finish) <u>L /R</u>

Clutch bell clearance 0.4 mm
 Spring Adj. Nut position 0.8 mm

Body

Type _____
 Wing _____

Drive ratio

1st 16 / 47
 2nd 20 / 43

Brake pad

Black Yellow

Result

Race time / Lap _____
 Best lap (1Lap) _____

Comments:

.....

